

Field Programmable Blank Oscillator

Series CPP

- Programmed with the PG-2000 field oscillator programming instrument within seconds
- Can be programmed twice
- Provides a sealed finished custom oscillator
- Standard Package Options

Part Numbering Example: CPP C 1 L Z - A5 B6 - XX.XXXX TS

CPP	C	1	L	Z	A5	B6	TS	
SERIES	OUTPUT	PACKAGE STYLE	VOLTAGE	ADDED FEATURES	OPERATING TEMP.	STABILITY	FREQUENCY	TRI-STATE
CPP	C = CMOS T = TTL	1 = Full Size 4 = Half Size 7 = 5X7 Ceramic 8 = PLASTIC SMD	Blank = 5V L = 3.3 V	Blank = Bulk T = Tube Z = Tape and Reel	Blank = 0°C +70°C A5 = -20°C +70°C A7 = -40°C +85°C	B6 = ±100 ppm BP = ±50 ppm	1.000–133.000 MHz	TS = Tri-State PD=PowerDwn

Specifications:

	Min	Typ	Max	Unit
Frequency Range: Programmable to Any Discrete Frequency	1.000		133.000	MHz
Available Stability Options:	-100 -50		100 50	ppm ppm
Programmable Input Voltage: (1–133 MHz)	+4.5	5.0	5.5	VDC
(1–100 MHz)	+3.0	3.3	3.6	VDC
Operating Temperature Range Options:	0 -20 -40		+70 +70 +85	°C °C °C
Storage Temperature:	-55		+125	°C
Aging (PPM/Year) Ta=25C, Vdd=5/3.3V			±5	
Programmable Output Level:	TTL/CMOS			
Packaging:	Tape and Reel (1K per Reel) Tube			

Note: Bypass Vdd to GND with a 0.1 mF capacitor

Operating Conditions:

	Description	Min	Max	Unit
V _{DD}	Digital Supply Voltage	3.0	5.5	V
C _{TTL}	Max Capacitive Load on outputs for TTL levels			
	4.5V–5.5V V _{DD} ≤ 40 MHz		50	pF
	4.5V–5.5V V _{DD} > 40–133 MHz		25	pF
C _{CMOS}	Max Capacitive Load on outputs for CMOS levels			
	4.5V–5.5V V _{DD} , ≤ 66 MHz		50	pF
	4.5V–5.5V V _{DD} , >66–133 MHz		25	pF
	3.0V–3.6V V _{DD} , ≤ 40 MHz		30	pF
	3.0V–3.6V V _{DD} , >40–100 MHz		15	pF



Field Programmable Blank Oscillator

Series CPP

- Programmed with the PG-2000 field oscillator programming instrument within seconds
- Can be programmed twice
- Provides a sealed finished custom oscillator

Electrical Characteristics

	TEST CONDITIONS	Min	Typ	Max	Unit
Input Characteristics (Pin 1):					
V _{IL} , Low-Level Input Voltage TO DISABLE OUTPUT	4.5–5.5V V _{DD}			0.8	V
	3.0–3.6V V _{DD}			0.2V _{DD}	V
V _{IH} , High-Level Input Voltage TO ENABLE OUTPUT OR NO CONNECT	4.5–5.5V V _{DD}	2.0			V
	3.0–3.6V V _{DD}	0.7V _{DD}			V
I _{IL} , Input Low Current	V _{IN} = 0V			10	mA
I _{IH} , Input High Current	V _{IN} = V _{DD}			5	mA
Output Characteristics:					
V _{OL} , Low-Level Output Voltage	4.5V–5.5V V _{DD} , 16 mA I _{OL}			0.40	V
	3.0V–3.6V V _{DD} , 8 mA I _{OL}			0.40	V
V _{OHTTL} , High-level Output Voltage TTL	4.5V–5.5V V _{DD} , -16 mA I _{OL}	2.40			V
V _{OHCMS} , High-level CMOS Voltage	4.5V–5.5V V _{DD} , -16 mA I _{OL}	V _{DD} -0.4			V
	3.0V–3.6V V _{DD} , -8 mA I _{OL}	V _{DD} -0.4			V
Power Supply Current: (unloaded)	4.5–5.5 V _{DD} , OUTPUT FREQ ≤ 133 MHz			45	mA
	3.0–3.6 V _{DD} , OUTPUT FREQ ≤ 100 MHz			25	mA
Standby Current:			10	50	mA
Input Pull-Up Resistor	4.5–5.5 V _{DD} , V _{IN} = 0V	1.1	3.0	8.0	MΩ
	4.5–5.5 V _{DD} , V _{IN} = 0.7V	50	100	200	kΩ
CLKOUT Pull-Down Current	5.0 V _{DD}		20		mA
Output Enable Mode:	Output is Tri-Stated				
Power Down Mode:	Output is <u>NOT</u> Tri-Stated.				



Field Programmable Blank Oscillator

Series CPP

- Programmed with the PG-2000 field oscillator programming instrument within seconds
- Can be programmed twice
- Provides a sealed finished custom oscillator

Output Clock Switching Characteristics

	TEST CONDITIONS	Min	Typ	Max	Unit
Duty Cycle: TTL @ 1.4 V, 4.5–5.5 V _{DD}	≤ 50 MHz, C _L = 50 pF	45		55	%
	50–66 MHz, C _L = 15 pF	45		55	%
	66–125 MHz, C _L = 25 pF	40		60	%
	125–133 MHz, C _L = 15 pF	40		60	%
CMOS @ V _{DD} /2, 4.5–5.5 V _{DD} 3.0–3.6 V _{DD}	≤ 66 MHz, C _L ≤ 25 pF	45		55	%
	66–125 MHz, C _L ≤ 25 pF	40		60	%
	125–133 MHz, C _L ≤ 15 pF	40		60	%
	≤ 40 MHz, C _L ≤ 30 pF	45		55	%
	40–100 MHz, C _L ≤ 15 pF	40		60	%
Output Clock Rise/Fall	0.8V–2.0V, 4.5-5.5 V _{DD} , C _L = 50			1.8	ns
	0.8V–2.0V, 4.5-5.5 V _{DD} , C _L = 25			1.2	ns
	0.8V–2.0V, 4.5-5.5 V _{DD} , C _L = 15			0.9	ns
	0.2–0.8V _{DD} , 4.5-5.5 V _{DD} , C _L = 50			3.4	ns
	0.2–0.8V _{DD} , 3.0–3.6 V _{DD} , C _L = 30			4.0	ns
	0.2–0.8V _{DD} , 3.0–3.6 V _{DD} , C _L = 15			2.4	ns
Start Up Time	From power on			10	ms
Power Down Delay Time	PWR_DWN pin HIGH to output LOW		T/2	T+10	ns
Output Disable Time	OE pin HIGH to output Hi-Z T = Frequency oscillator period		T/2	T+10	ns
Output Enable Time				100	ns
RMS Jitter	≤ 33.000, 5 V			± 50	ps
	> 33.000, 5 V			± 30	ps
	≤ 33.000, 3 V			± 50	ps
	> 33.000, 3 V			± 40	ps



Field Programmable Blank Oscillator

Series **CPP**

- Programmed with the PG-2000 field oscillator programming instrument within seconds
- Can be programmed twice
- Provides a sealed finished custom oscillator

Style 1 Full Size 14 Pin Dip

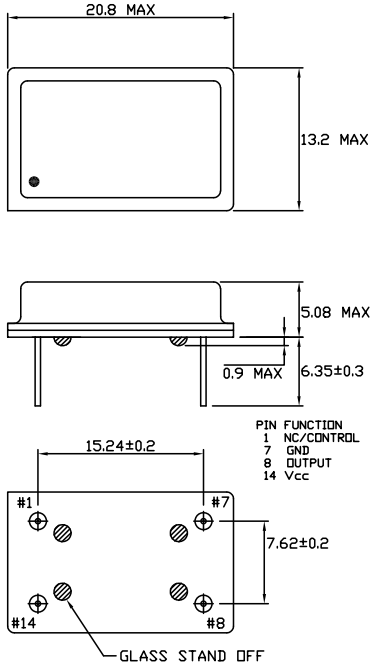

Style 4 Half Size 8 Pin Dip

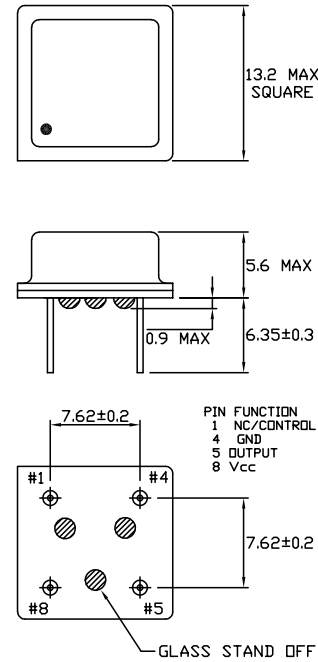

Style 7 5x7 Ceramic SMD

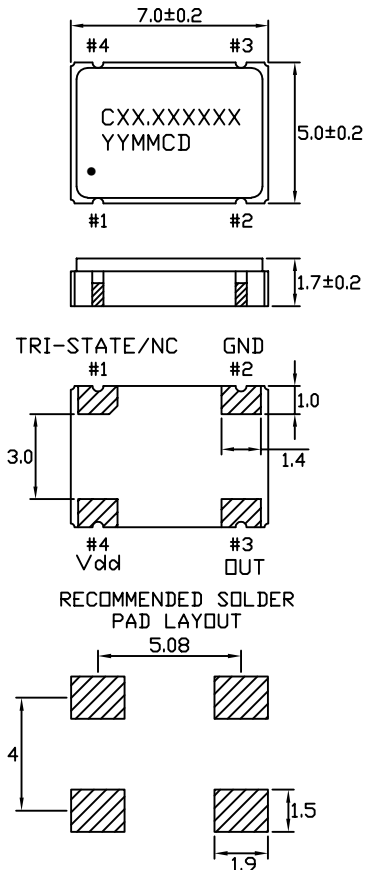

Style 8 Plastic SMD

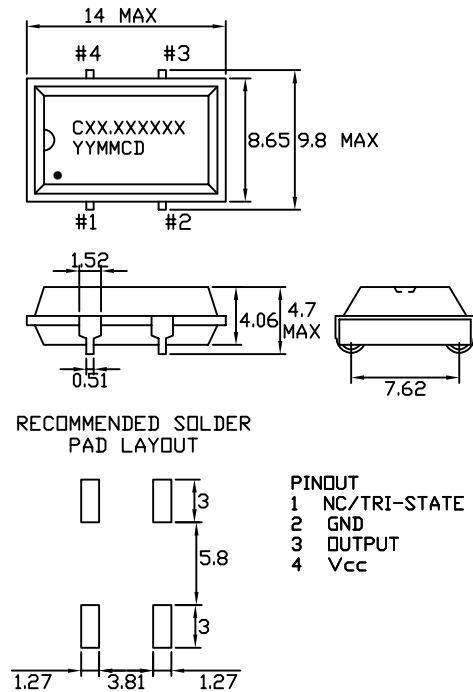

Field Oscillator Programming Instrument

Series **PG-2000**

- *Programming instrument to create oscillators, at a user specified frequency, within seconds IN THE FIELD*
- *No programming skills needed to create finished oscillators from sealed oscillator blanks*
- *Programmable CMOS or TTL oscillator outputs*
- *Programmable output enable and power-down feature*
- *Programmable asynchronous or synchronous output enable*
- *Programmable for 3.3V or 5.0V oscillator operation*
- *Microsoft Windows compatible software*

Instrument Part Number: PG-2000

Specifications:

Frequency Range:	1.000 MHz to 133.000 MHz
Acceptable Oscillator Packages:	Style 1 Full-Size 14 Pin DIP Style 4 Half-Size 8 Pin DIP SMD
Oscillator Programming Options:	Output Enable Function Power Down Operation TTL or CMOS Output Instantaneous Asynchronous/ Synchronous Enable/Power Down Selectable Input Voltage (3.3, 5.0V) Ability to reprogram oscillator blank to reuse the same part for two separate applications with different frequency and/or different output characteristics
Transformer	AC, Supplied. UL 996C / 820A0063
Input:	100 - 250 VAC 60 Hz 20 W
Output:	16 VAC 750 mA
Instrument Size:	6.5" x 10.5" x 2.5"
Oscillator Blank Part Numbers:	see Cardinal CPP series
Required Additional Equipment:	IEEE-488 Instrument Control Card (HP 82341D or eq.) IEEE-488 Instrument Control Cable (HP 10833B, or eq) Frequency Counter (HP 53131 or eq) Computer w/ Microsoft Windows 95,98,NT or Windows 2000

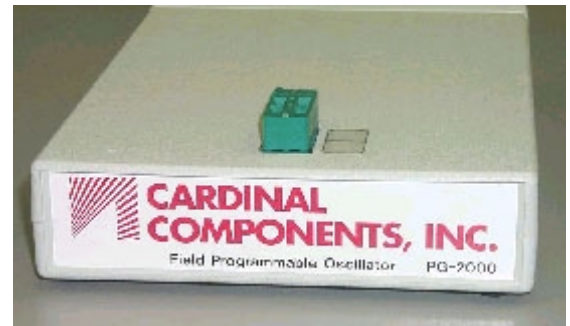

Stand-Alone Field Oscillator Programming Instrument

Series **PG-2000P**

- *Programming instrument to create oscillators, at a user specified frequency, within seconds **IN THE FIELD***
- *No programming skills needed to create finished oscillators from sealed oscillator blanks*
- *Designed for low-volume program applications such as engineering, field sales, and sample quantity*
- *Internal frequency reference for single step programming*
- *Simple User Interface*
- *Cardinal 4-pin oscillators are easily inserted into a ZIF socket or surface mount adapter for quick programming*
- *Oscillator characteristics are selected via keypad and 4-line LCD display*

Instrument Part Number: PG-2000P

Specifications:

Frequency Range:	1.000 MHz to 133.000 MHz
Acceptable Oscillator Packages:	Style 1 Full-Size 14 Pin DIP Style 4 Half-Size 8 Pin DIP SMD (With Optional SC-2000 Adapter)
Programmable Voltage Range:	3.3, 5.0 V
User Interface:	4 Line LCD frequency control parameters usage instructions helpful error messages Keypad ZIF Socket
Design Specifications:	For use with 4-pin oscillators
Oscillator Programming Options:	control pin functionality outputs electrical characteristics Ability to reprogram oscillator blank to correct errors or to reuse the same part for two sperate applications with different frequency and/or different output characteristics
Switching Power Supply	Equipped with Universal AC pwr supply UL 1950
Input:	100 - 250 VAC 50/60 Hz 0.7 – 0.35 A
Output:	+ 5.0 V 1.0 A +15.0 V 0.4 A - 15.0 V 0.4 A
Instrument Size:	10" x 4.75" x 2.65"
Oscillator Blank Part Numbers:	see Cardinal CPP series

